

Skate CX

Art.-Nr. 93060



- 1) Rokamat Skate CX (25-08SKCX0001)
- 2) 2006/42/EG, 2011/65/EU, 2014/30/EU, 2012/19/EU, 2001/95/EG, EG No. 1907/2006, EU 2023/988
- 3) EN ISO 12100:2010, EN 62841-1:2015 + AC:2015 + A11:2022, EN 62841-2-4:2014 /AC:2015, EN IEC 62841-2-3:2021/A11:2021, EN IEC 63000:2018, EN 55014-1:2017 + A11:2020, EN 55014-2:1997 + AC:1997 + A1:2001 + A2:2008
- 4) Kammerer GmbH, An der B 10, 75196 Remchingen

Remchingen, 01.08.2025

Beate Kammerer
Head of Technical Documentation



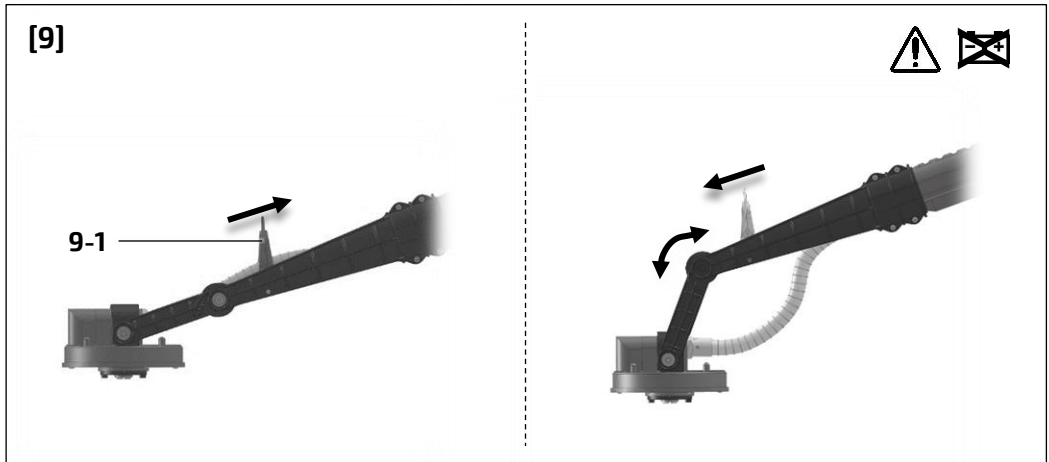
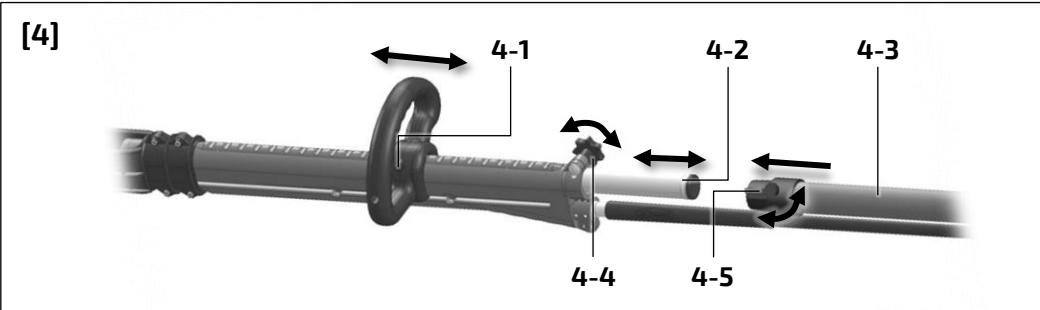
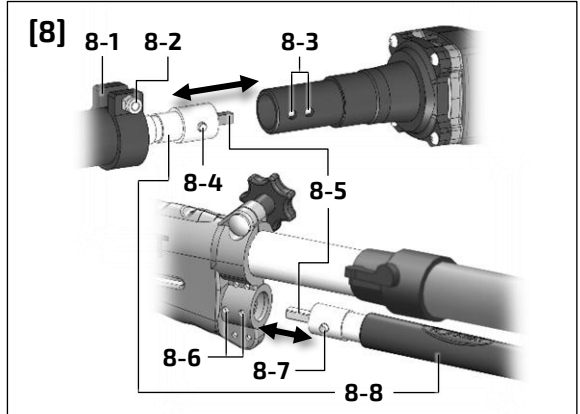
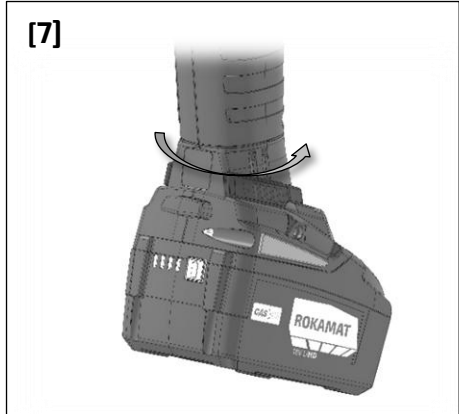
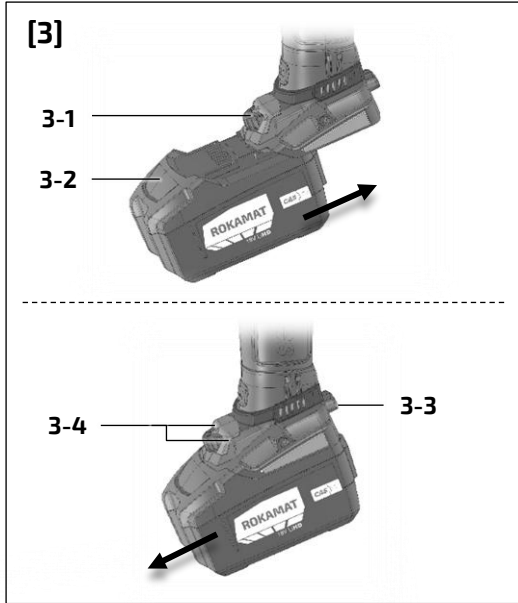
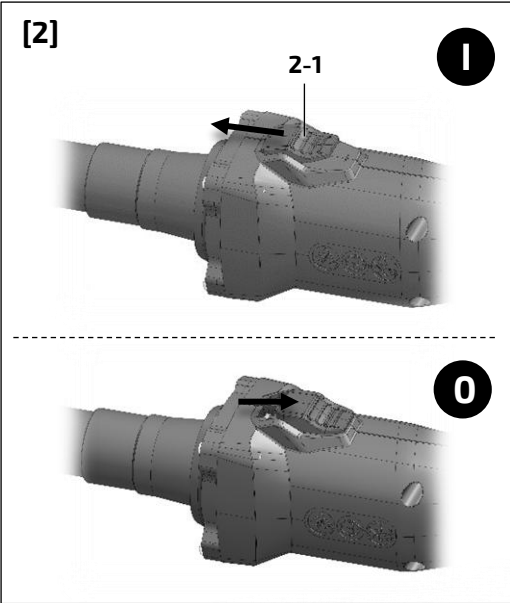
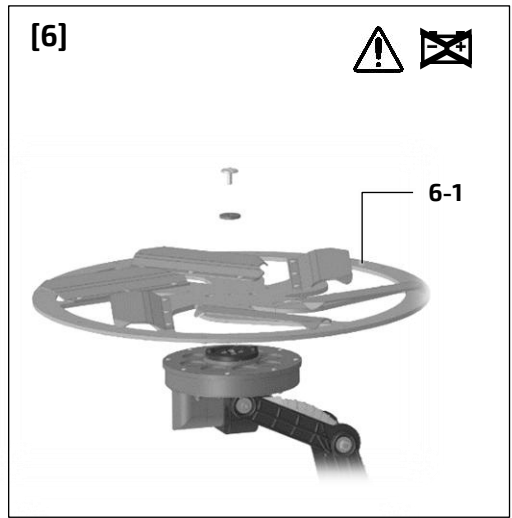
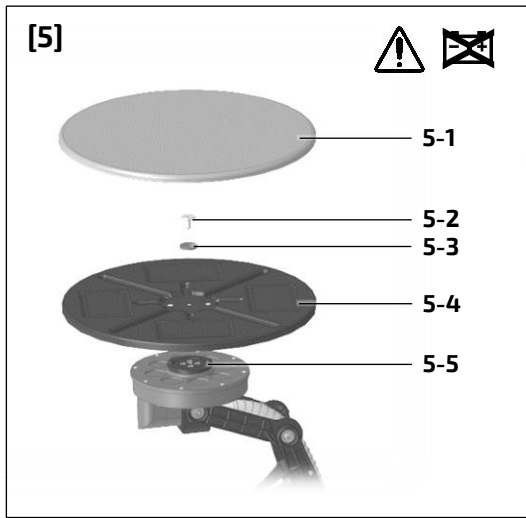
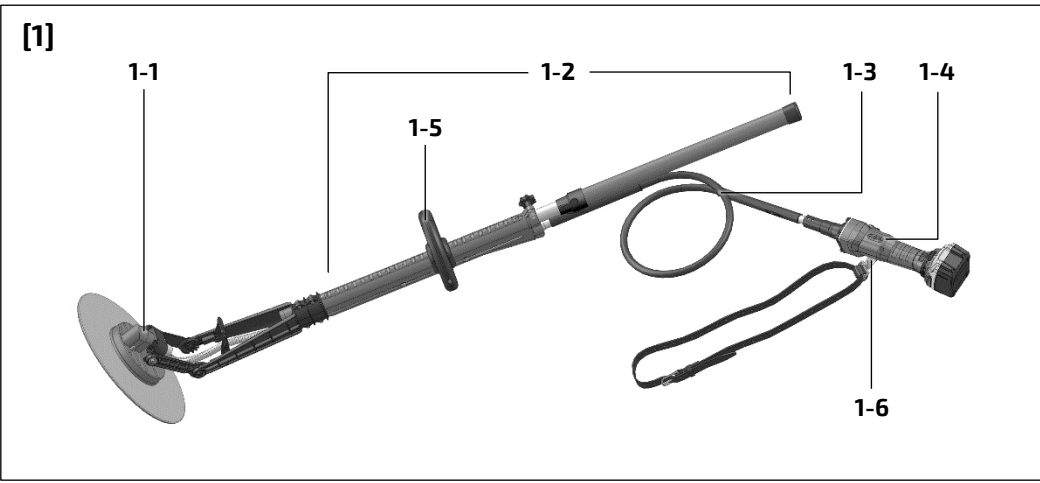

Contents

| | |
|---------------------------------------|---|
| 1. Symbols | 3 |
| 2. Safety Instructions | 3 |
| 3. Intended Use | 4 |
| 4. Technical Specifications | 4 |
| 5. Device Components | 4 |
| 6. Commissioning | 4 |
| 7. Instructions for Use | 4 |
| 8. Working with the Power Tool | 5 |
| 9. Maintenance and Care | 5 |
| 10. Spare Parts and Accessories | 5 |
| 11. Environmental Protection | 5 |
| 12. Declaration of Conformity | 5 |
| 13. Troubleshooting | 6 |

1. Symbols



WARNING! Denotes impending danger. Non-observance of this warning may result in death or extremely severe injuries. *)



CAUTION! Denotes a possibly dangerous situation. Non-observance of this warning may result in slight injury or damage to property. *)



Risk of electric shock!



Read operating instructions and safety notices! *)



Wear protective goggles! *)



Wear ear protection!



Two-hand operation. *)



Do not dispose of as domestic waste! *)



Important advice/information



CAS Li-Ion battery pack *)



Removing battery pack!

1, 2, 3 ... Thumbwheel settings (Speed settings. Higher number means greater speed) *)

d.c. Direct Current (DC) *)

CE Confirms the conformity of the power tool with the directives of the European Community. *)

*) These symbols are (also) on the device.

2. Safety Instructions

For your safety



WARNING

Read all safety warnings, instructions, illustrations and specifications provided with this power tool. Failure to follow all instructions listed below may result in electric shock, fire and/or serious injury.

Save all warnings and instructions for future reference.



Do not use this power tool before you have thoroughly read and completely understood this Instruction Manual, the enclosed "General Power Tool Safety Warnings", instructions for battery packs and chargers.

The documents mentioned should be enclosed with the power tool, should it be passed on or sold.

Please also observe the relevant national industrial safety regulations.

Special Safety Instructions

Safety Warnings common for Concrete Power Trowel:

- This power tool is designed to be used as a concrete power trowel. Read all safety warnings, instructions, illustrations and specifications provided with this power tool. Failure to follow all instructions listed below may result in electric shock, fire and/or serious injury.**
- Operations such as grinding, sanding with a wire brush and sandpaper, polishing and abrasive cutting are not to be performed with this power tool. Operations for which the power tool was not designed may create a hazard and cause personal injury.**
- Do not convert this power tool to operate in a way which is not specifically designed and specified by the tool manufacturer. Such a conversion may result in a loss of control and cause serious personal injury.**
- Do not use accessories which are not specifically designed and specified by the tool manufacturer. Just because the accessory can be**

attached to your power tool, it does not assure safe operation.

- The rated speed of the accessory must be at least equal to the maximum speed marked on the power tool. Accessories running faster than their rated speed can break and fly apart.**
- The outside diameter and the thickness of your accessory must be within the capacity rating of your power tool. Incorrectly sized accessories cannot be adequately guarded or controlled.**
- Threaded mounting of accessories must match the grinder spindle thread. For accessories mounted by flanges, the arbor hole of the accessory must fit the locating diameter of the flange. Accessories that do not match the mounting hardware of the power tool will run out of balance, vibrate excessively and may cause loss of control.**
- Do not use a damaged accessory. Before each use inspect the accessory such as abrasive wheels for chips and cracks, backing pad for cracks, tear or excess wear, wire brush for loose or cracked wires. If power tool or accessory is dropped, inspect for damage or install an undamaged accessory. After inspecting and installing an accessory, position yourself and bystanders away from the plane of the rotating accessory and run the power tool at maximum no-load speed for one minute. Damaged accessories will normally break apart during this test time.**
- Wear personal protective equipment. Depending on application, use face shield, safety goggles or safety glasses. Where appropriate, wear dust mask, hearing protectors, gloves and workshop apron capable of stopping small abrasive or workpiece fragments. The eye protection must be capable of stopping flying debris generated by various operations. The dust mask or respirator must be capable of filtering particles generated by your operation. Prolonged exposure to high intensity noise may cause hearing loss.**
- Keep bystanders a safe distance away from work area. Anyone entering the work area must wear personal protective equipment. Fragments of workpiece or of a broken accessory may fly away and cause injury beyond immediate area of operation.**
- Hold the power tool by insulated gripping surfaces only, when performing an operation**

where the cutting accessory may contact hidden wiring. Cutting accessory contacting a "live" wire may make exposed metal parts of the power tool "live" and could give the operator an electric shock.

- Never lay the power tool down until the accessory has come to a complete stop. The spinning accessory may grab the surface and pull the power tool out of your control.**
- Do not run the power tool while carrying it at your side. Accidental contact with the spinning accessory could snag your clothing, pulling the accessory into your body.**
- Regularly clean the power tool's air vents. The motor's fan will draw the dust inside the housing and excessive accumulation of powdered metal may cause electrical hazards.**
- Do not operate the power tool near flammable materials. Sparks could ignite these materials.**
- Do not use accessories that require liquid coolants. Using water or other liquid coolants may result in electrocution or shock.**

Kickback and related warnings

Kickback is a sudden reaction to a pinched or snagged rotating wheel, backing pad, brush or any other accessory. Pinching or snagging causes rapid stalling of the rotating accessory which in turn causes the uncontrolled power tool to be forced in the direction opposite of the accessory's rotation at the point of the binding.

For example, if an abrasive wheel is snagged or pinched by the workpiece, the edge of the wheel that is entering into the pinch point can dig into the surface of the material causing the wheel to climb out or kick out. The wheel may either jump toward or away from the operator, depending on direction of the wheel's movement at the point of pinching. Abrasive wheels may also break under these conditions.

Kickback is the result of power tool misuse and/or incorrect operating procedures or conditions and can be avoided by taking proper precautions as given below.

- Maintain a firm grip on the power tool and position your body and arm to allow you to resist kickback forces. Always use auxiliary handle, if provided, for maximum control over kickback or torque reaction during start-up. The operator can control torque reactions or**

kickback forces, if proper precautions are taken.

- b) **Never place your hand near the rotating accessory.** Accessory may kickback over your hand.
- c) **Do not position your body in the area where power tool will move if kickback occurs.** Kickback will propel the tool in direction opposite to the wheel's movement at the point of snagging.
- d) **Use special care when working corners, sharp edges, etc. Avoid bouncing and snagging the accessory.** Corners, sharp edges or bouncing have a tendency to snag the rotating accessory and cause loss of control or kickback.
- e) **Do not attach a saw chain woodcarving blade or toothed saw blade.** Such blades create frequent kickback and loss of control over the power tool.

Additional safety instructions

Damaged, eccentric or vibrating tools must not be used.

Safety instructions for the protection of the electrical appliance

Never immerse the machine in water or spray it with water for cleaning, not even the tool holder!

Don't bend the flexible drive shaft!

Do not overload the motor for a long period. Engine noise should be regular (not wave-like). Unsteady engine performance can be perceived acoustically.

Take a break when the machine is heated up strongly and let it cool down again. To that let the motor idle at top speed for some time.

Don't put the running motor on the ground! Dirt may get sucked in and cause damage.

Emission levels

NOTE! Values for the A-weighted sound pressure level and for the total vibration values can be found in the "Technical specifications" table at chapter 4.

These values have been measured in accordance with a standardised test and may be used to compare one tool with another. They may also be used for a preliminary assessment of exposure.

CAUTION! The indicated measurements refer to new power tools represent the main applications of the tool. However, if the tool is used for different applications, with different accessories or poorly maintained, the vibration and noise emissions

during actual use of the power tool may differ from the declared values (significantly increased over the total working period).



CAUTION! During operation the noise level can exceed 80 dB(A).

Wear ear protection!

Identify additional safety measures to protect the operator from the effects of vibration such as: maintain the tool and the accessories, keep the hands warm, organization of work patterns. An estimation of the level of exposure to vibration should also take into account the times when the tool is switched off or when it is switched on but running without load. This may significantly reduce the exposure level over the total working period.

Environmental conditions for machine, battery and charger

Operation

Temperature range: 0 °C to +50 °C

Humidity: ≤ 85 %, non-condensing

Climate: dry

Transport and storage

Temperature range tool: -5°C to +55°C

Temperature range battery: +10 °C and +30 °C

Humidity: 0 % to 70 %

Climate: dry, roofed, dew protected

3. Intended Use

The hand-held battery tool **Rokamat Skate CX** is intended for leveling and troweling fresh concrete, screed and similar indoors and outdoors. Activities where the operator is in a conductive environment (e.g. activity on liquid concrete, reinforcement, etc.) require additional protective measures against electric shock (e.g. a residual current device). National regulations must be respected.

This power tool is intended for use only with approved original ROKAMAT tools and accessories, as specified in the operating instructions.

Only sufficiently qualified and trained personnel is allowed to work with the *Chameleon CX*.

The intended use includes the observance of the operating instructions, in particular the safety instructions and the observance of generally recognized accident prevention regulations.

Any use other than the intended use described above is considered misuse. The manufacturer accepts no liability or warranty for misuse of the machine.

4. Technical Specifications

| Cordless concrete power trowel <i>Skate CX</i> Item No. 93060 | |
|--|--------------------------|
| Rated voltage | 18 V DC |
| No-load speed | 75-250 min ⁻¹ |
| Maximum tool diameter | 450 mm |
| Driver disc | Clamping screw M6 |
| Total weight | 5,4 kg |
| Dimension compact (LxHxW) | 1135x200x420 mm |
| A-weighted sound pressure level (see cap. 2 "Emission levels"): | |
| Sound pressure level L _{pA} | 81 dB(A) |
| Sound power level L _{WA} | 92 dB(A) |
| Uncertainty K | 3,0 dB |
| Total vibration value (see cap. 2 "Emission levels"): | |
| Emission value a _h | 2,0 m/s ² |
| Uncertainty K | 1,5 m/s ² |

5. Device Components

The specified illustrations can be found in fig. [1] on page 2 of the operating instructions.

- 1-1 Tool holder
- 1-2 Gripping surface
- 1-3 Flexible drive shaft
- 1-4 Motor (gripping surface)
- 1-5 Handle
- 1-6 Fastening ring for the (shoulder) belt

6. Commissioning



CAUTION

Before switching on the power tool: Unpack power tool and accessories and check that no parts are missing or damaged.

Do not use this power tool until you have thoroughly read and fully understood the separate operating instructions for the battery packs and chargers.

Motor mounting [1]

The motor [1-4] is not allowed to be placed on the floor during operation, but must be hooked in the carabiner of the provided belt (resp. shoulder belt).

Switching the electric power tool on and off [2]

Switching on: Push the sliding switch [2-1] forward. For continuous activation, now tilt downwards until it engages.

Switching off: Press the rear end of the slide switch [2-1] and release it.

7. Instructions for Use



WARNING

Risk of injury, electric shock!

Always remove the battery pack before performing any type of work on the machine!

Only use CAS-compatible chargers / batteries with a rated voltage of 18 V DC!

Installing or removing battery pack [3]

To insert: Slide the battery pack [3-2] in until it engages.

To remove: Press the battery pack release button [3-3] and pull the battery pack [3-2] downwards and out.

Adjusting the speed

Set the recommended speed using the thumbwheel [3-1]. (Lower number = lower speed; higher number = higher speed).

Rotating battery pack [7]

The rear section of the machine can be rotated 270° in three stages, thus allowing the machine's shape to be adapted to the working conditions. Only operate the machine when it is in an engaged position.

Attaching/removing the supporting plate [5]

- Loosen the clamping screw [5-2] and remove it together with the rubber washer [5-3].
- The supporting plate [5-4] can be detached/removed.
- Attaching in reverse order. Ensure that both pins on the driver disc [5-5] mate with the drill holes in the supporting plate.

Attaching, changing or removing the trowel with Velcro [5]

- Place the trowel [5-1] in the center of the supporting plate [5-4] and press on.
- Conduct a test run to check that the trowel is attached in the center.

Attaching, changing or removing the trowel with blades [6]

| | |
|--|-----------------|
|  | CAUTION! |
| <p>Never attach the trowel with blades without rubber washers! The rubber washers are needed to prevent the clamping screws from coming loose during operation.</p> | |

- The supporting plate [5-4] must be removed before the trowel [6-1] is mounted (see above).
- Centre trowel directly on the driver disc [5-5]. Ensure that both pins on the driver disc mate with the drill holes in trowel.
- Then turn the clamping screw [5-2] clockwise together with the rubber washer [5-3] to tighten them.
- Removing in reverse order.

Angle adjustment [9]

- Pull lever [9-1].
- Set the desired angle.
- Release lever and allow bolt [9-1] to engage.

The angle adjustment allows for ergonomic work. It should also be ensured that the abrasive always lies *parallel* on the surface to be worked on.

Handle [4]

- Push in the bolt [4-1] on the handle [1-5].
- Move handle [1-5] to desired position.
- Loosen bolt [4-1] and allow to engage.

Telescopic tube [4]

- Open the clamping screw [4-4].
- Move the telescopic tube [4-3] to the desired position.
- Lock the clamping screw [4-4].

Handle extension [4]

- Loosen clamping lever [4-5].
- Push handle extension [4-3] onto the handhold [4-2] and to the desired position.
- Lock the clamping lever [4-5].

8. Working with the Power Tool



1. Attach trowel.
2. Attach motor to (shoulder) belt.
3. Insert the battery pack.
4. Hold the power trowel with both hands at the gripping surfaces.
5. Switch on the device.
6. Press the trowel gently against the work surface.
7. Increase the pressure to bring the sanding sheet into contact with the work surface.

After finishing work

| | |
|---|----------------|
|  | CAUTION |
| <p>Risk of damage to the device! Do not set the power tool down with the tool disc facing downwards!</p> | |

Once you have finished the troweling work, set the power tool down.

9. Maintenance and Care

| | | | |
|---|---|---|----------------|
|  |  |  | WARNING |
| <p>Risk of injury, electric shock! Always be sure that the tool is switched off and the battery pack is removed before performing maintenance work on the machine!</p> | | | |

| | |
|--|----------------|
|  | CAUTION |
| <p>Risk of damage to the device! Never immerse the tool holder in water or spray it with water to clean it!</p> | |

Repairs may be carried out by an authorized customer service center only.

Repairs to electrical tools must be carried out by qualified electricians only!

During the warranty period do not loosen the screws on the housing. Non-compliance will deem the warranty obligations of the manufacturer null and void.

Transport and storage

| | |
|---|-----------------|
|  | WARNING! |
| <p>Risk of damage to the power tool! Remove the battery from the tool before transporting it! Transport and store the power tool only in its original carrying case.</p> | |

Remove dust from the motor and battery regularly

It is possible that particles deposit inside the power tool during operation. This impairs the cooling of the power tool. Conductive build-up can impair the protective insulation of the power tool and cause electrical hazards.

The power tool should be cleaned regularly, often and thoroughly through all front and rear air vents using a vacuum cleaner or by blowing in dry air. Prior to this operation, remove the battery pack and wear protective glasses and dust mask.

Replacement of the flexible drive shaft [8]

| | |
|--|----------------|
|  | CAUTION |
| <p>Risk of damage to the device! The two boreholes for the push button at the drive shaft serve as length adjustment between shaft core and protective hose. The shaft core should be freely movable in length and must not get compressed!</p> | |

Disassembling: First loosen the nut [8-2] on the clamping ring [8-1]. Then press in the press button [8-4] in the borehole [8-3] with a tool (e.g. screwdriver) and pull out the protective hose [8-8]. Now the shaft core [8-5] can be replaced.

To replace the protective hose [8-8], it must also be loosened on the side of the tool holder. To do this, press in the press button [8-7] in the borehole [8-6] with a tool (e.g. screwdriver) and pull out the protective hose [8-8].

Mounting: In reverse order. Make sure that the shaft core [8-5] is threaded into the square in each case.

| | |
|---|---------------|
|  | ADVICE |
| <p>Check all wearing parts once a month.</p> | |

10. Spare Parts and Accessories

Other accessories, in particular insertion tools, can be found in the manufacturer's catalogues. Exploded drawings and spare-part lists can be found on our homepage: www.rokamat.com.

Use only original ROKAMAT spare parts and work tools!

11. Environmental Protection

Observe national regulations on environmentally compatible disposal and on the recycling of disused machines, packaging and accessories.



Li-ion

For Great Britain and EU countries: Do not dispose of electric equipment or battery pack together with household waste material! In observance of the European Directives, on Waste Electric and Electronic Equipment and Batteries and Accumulators and Waste Batteries and Accumulators and their implementation in accordance with national laws, electric equipment and batteries and battery pack(s) that have reached the end of their life must be collected separately and returned to an environmentally compatible recycling facility.

| | |
|---|---------------|
|  | ADVICE |
| <p>Please ask your dealer about disposal options!</p> | |

12. Declaration of Conformity

It is expressly declared that the cordless grinder listed on the first page under 1) from the serial number indicated onwards complies with all relevant provisions of the directives or regulations listed in 2) and that the harmonized standards listed in 3) have been applied. The technical documentation is available from the authorized documentation agent named in 4).

13. Troubleshooting

| Problem | Possible causes | Remedy |
|---|---|--|
| Motor runs, but the supporting plate does not rotate. | Shaft core broken. | Exchange shaft core. |
| | Mitre-gear of the tool holder is defective. | Replace the mitre-gear with case top. |
| The electronic signal display [3-4] lights up and the load speed decreases. | There has been an overload while working, therefore the performance may be reduced temporarily. | Reduce working pressure. |
| The machine does not start. The electronic signal display [3-4] flashes. | The battery is empty, the temperature is too high or the restart protection has triggered. | Switch the machine off and back on again. The machine will not start if the battery pack is inserted while the machine is on. When using a battery pack that is not part of CAS, the machine will not start. |
| Skate CX not working. | Battery discharged. | Charge battery. |
| Skate CX does not run smoothly over the surface. | Trowels not mounted correctly. | Check that the trowels are correctly seated. |
| | Deformed trowel. | Use a new trowel. |
| Groove formation on the surface. | Wrong speed set. | Adjust speed. |
| | Material to be processed is too moist. | Allow material to dry longer. |
| | Too much pressure on the surface. | Reduce contact pressure. |

If problems other than those listed occur, please contact your ROKAMAT service workshop or your local specialist.