

Chameleon CX

Art.-Nr. 26000

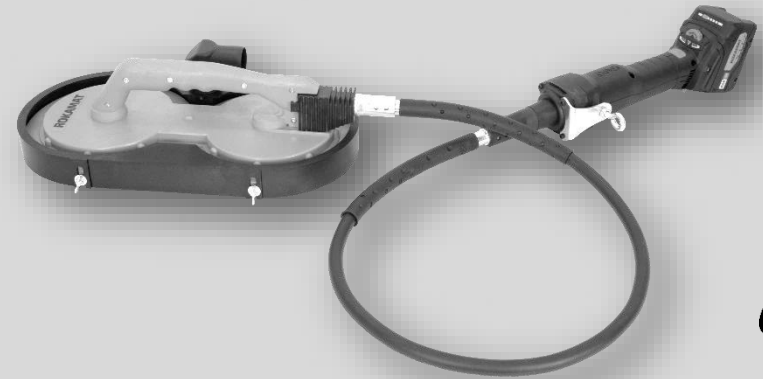

CAS



- 1) Rokamat Chameleon CX (25CHCX0001)
- 2) 2006/42/EG, 2011/65/EU, 2014/30/EU, 2012/19/EU, 2023/988, EG No. 1907/2006
EN 62841-1:2015 + AC:2015 + A11:2022, EN 62841-2-4:2014 /AC:2015,
EN IEC 62841-2-3:2021/A11:2021, EN IEC 63000:2018, EN 55014-1:2017
+ A11:2020, EN 55014-2:1997 + AC:1997 + A1:2001 + A2:2008
- 3) Kammerer GmbH, An der B 10, 75196 Remchingen

Remchingen, 01.08.2025

A handwritten signature in black ink, appearing to read 'BK'.

Beate Kammerer
Head of Technical Documentation

ROKAMAT

Kammerer GmbH
An der B 10
75196 Remchingen
Deutschland



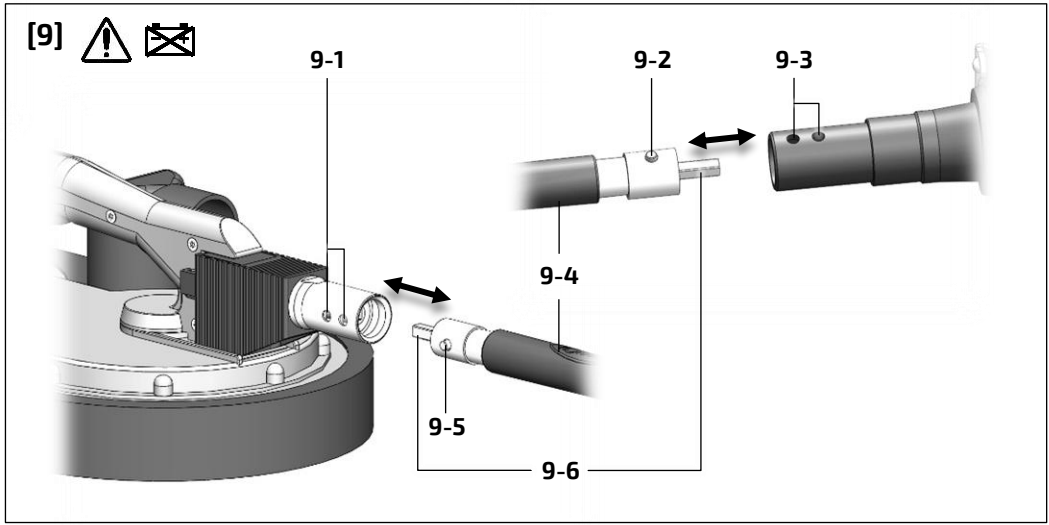
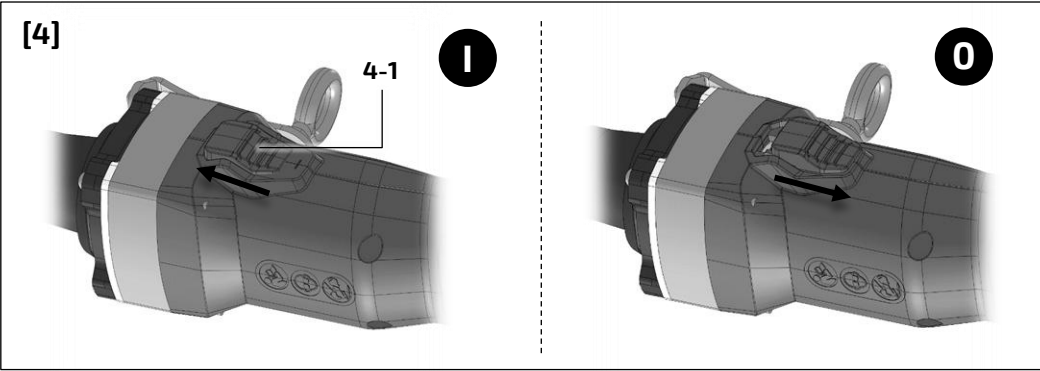
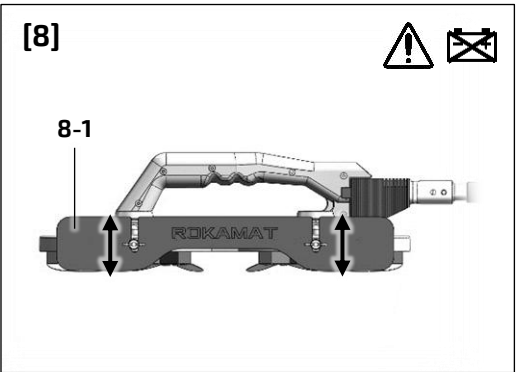
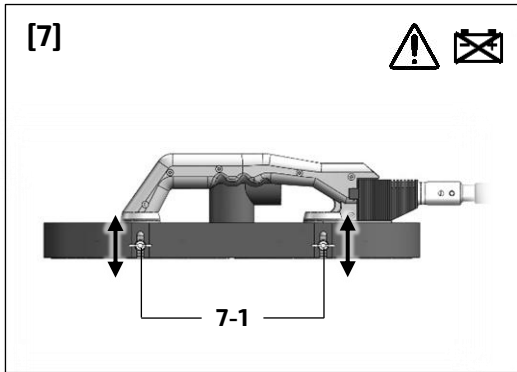
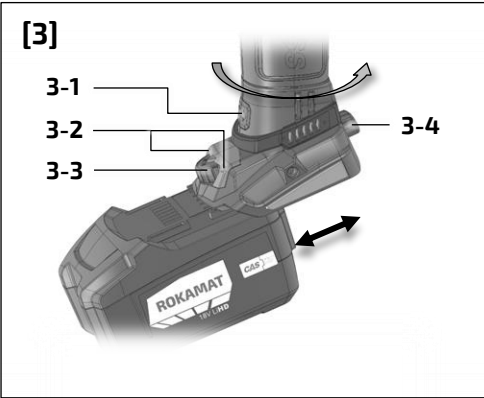
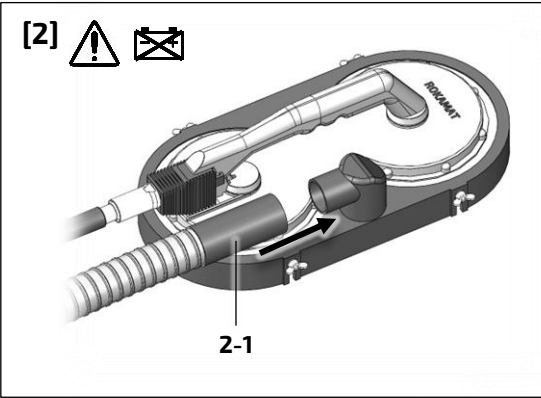
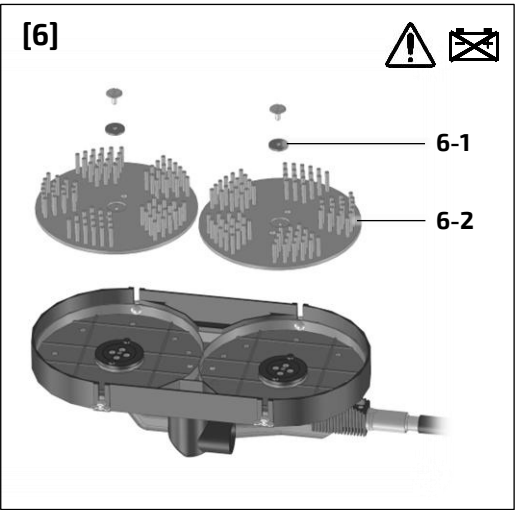
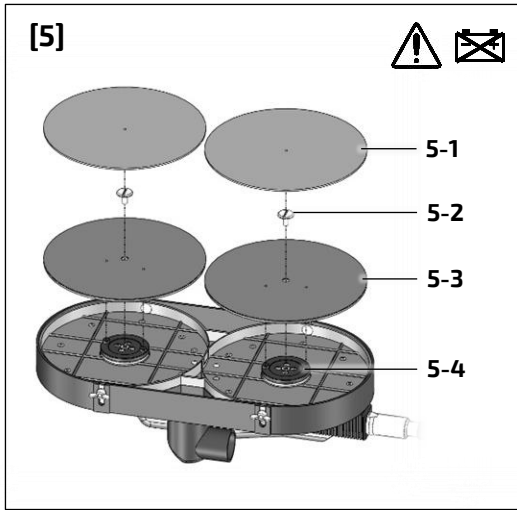
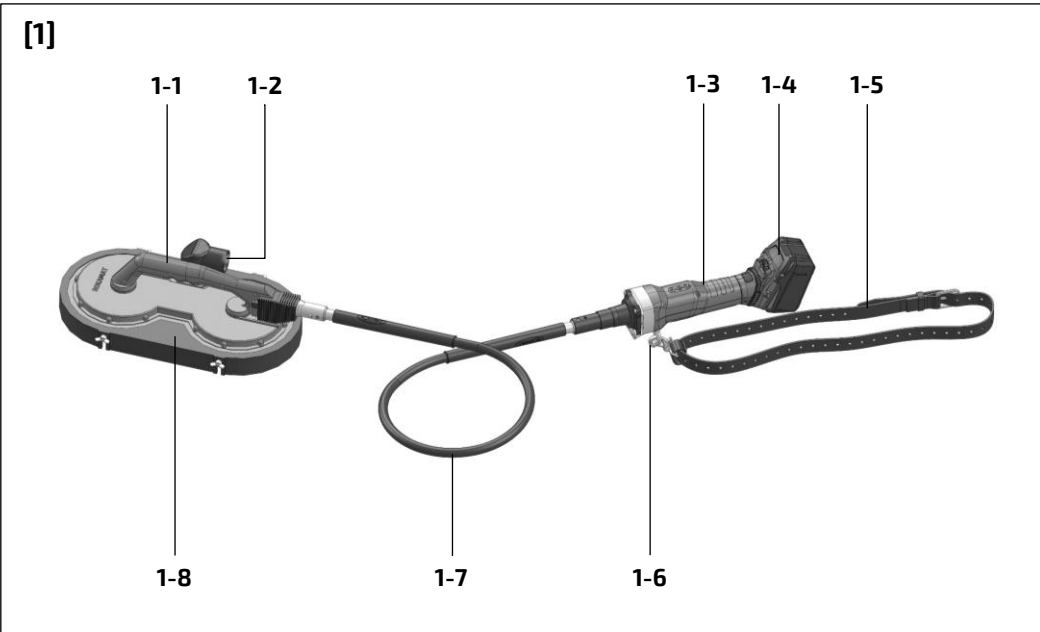

Inhaltsverzeichnis

1. Symbols	3
2. Safety Instructions	3
3. Intended Use	4
4. Technical Specifications	5
5. Device Components	5
6. Commissioning	5
7. Instructions for Use	5
8. Working with the Power Tool	5
9. Maintenance and Care	6
10. Spare Parts and Accessories	6
11. Environmental Protection	6
12. Declaration of Conformity	6
13. Troubleshooting	7

1. Symbols



WARNING! Denotes impending danger. Non-observance of this warning may result in death or extremely severe injuries. *)



CAUTION! Denotes a possibly dangerous situation. Non-observance of this warning may result in slight injury or damage to property. *)



Risk of electric shock!



Read operating instructions and safety notices! *)



Wear protective goggles! *)



Wear ear protection!



Wear a dust mask!



Two-hand operation. *)



CAS Li-Ion battery pack *)



Removing battery pack!



Do not dispose of as domestic waste! *)



Important advice/information

1, 2, 3... Thumbwheel settings (Speed settings. Higher number means greater speed) *)

d.c. Direct Current (DC) *)



Confirms the conformity of the power tool with the directives of the European Community. *)

*) These symbols are (also) on the device.

2. Safety Instructions

For your safety



WARNING!

Read all safety warnings, instructions, illustrations and specifications provided with this power tool. Failure to follow all instructions listed below may result in electric shock, fire and/or serious injury.

Save all warnings and instructions for future reference.



Do not use this power tool before you have thoroughly read and completely understood this Instruction Manual, the enclosed "General Power Tool Safety Warnings", instructions for battery packs and chargers.

The documents mentioned should be enclosed with the power tool, should it be passed on or sold.

Please also observe the relevant national industrial safety regulations.

Special Safety Instructions

Safety Warnings Common for Grinding, Sanding, Wire Brushing or Polishing Operations

- a] **This power tool is intended to function as a grinder, sander, wire brush, or polisher. Read all safety warnings, instructions, illustrations and specifications provided with this power tool.** Failure to follow all instructions listed below may result in electric shock, fire and/or serious injury.
- b] **Operations such as hole cutting or cutting-off are not to be performed with this power tool.** Operations for which the power tool was not designed may create a hazard and cause personal injury.
- c] **Do not convert this power tool to operate in a way which is not specifically designed and specified by the tool manufacturer.** Such a conversion may result in a loss of control and cause serious personal injury.
- d] **Do not use accessories which are not specifically designed and specified by the tool**

manufacturer. Just because the accessory can be attached to your power tool, it does not assure safe operation.

- e] **The rated speed of the accessory must be at least equal to the maximum speed marked on the power tool.** Accessories running faster than their rated speed can break and fly apart.
- f] **The outside diameter and the thickness of your accessory must be within the capacity rating of your power tool.** Incorrectly sized accessories cannot be adequately guarded or controlled.
- g] **The dimensions of the accessory mounting must fit the dimensions of the mounting hardware of the power tool.** Accessories that do not match the mounting hardware of the power tool will run out of balance, vibrate excessively and may cause loss of control.
- h] **Do not use a damaged accessory. Before each use inspect the accessory for chips and cracks, tear or excess wear. If power tool or accessory is dropped, inspect for damage or install an undamaged accessory. After inspecting and installing an accessory, position yourself and bystanders away from the plane of the rotating accessory and run the power tool at maximum no-load speed for one minute.** Damaged accessories will normally break apart during this test time.
- i] **Wear personal protective equipment. Depending on application, use face shield, safety goggles or safety glasses. As appropriate, wear dust mask, hearing protectors, galoves and workshop apron capable of stopping small workpiece fragments.** The eye protection must be capable of stopping flying debris generated by various applications. The dust mask or respirator must be capable of filtering particles generated by the particular application. Prolonged exposure to high intensity noise may cause hearing loss.
- j] **Keep bystanders a safe distance away from the work area. Anyone entering work area must wear personal protective equipment.** Fragments of a broken accessory may fly away and cause injury beyond immediate area of operation.
- k] **Hold the power tool by insulated gripping surfaces only, when performing an operation where the cutting accessory may contact hidden wiring.** Contact with a "live" wire will also make exposed metal parts of the power tool

"live" and could give the operator an electric shock.

- l] **Never lay the power tool down until the accessory has come to a complete stop.** The spinning accessory may grab the surface and pull the power tool out of your control.
- m] **Do not run the power tool while carrying it at your side.** Accidental contact with the spinning accessory could snag your clothing, pulling the accessory into your body.
- n] **Regularly clean the power tool's air vents.** The motor's fan will draw the dust inside the housing and excessive accumulation of powdered metal may cause electrical hazards.
- o] **Do not operate the power tool near flammable materials.** Sparks could ignite these materials.
- p] **Do not use accessories that require liquid coolants.** Using water or other liquid coolants may result in electrocution or shock.

Kickback and related warnings

Kickback is a sudden reaction to a pinched or snagged rotating backing pad or any accessory. Pinching or snagging causes rapid stalling of the rotating accessory which in turn causes the uncontrolled power tool to be forced in the direction opposite of the accessory's rotation at the point of the binding.

For example, if an abrasive wheel is snagged or pinched by the workpiece, the edge of the wheel that is entering into the pinch point can dig into the surface of the material causing the wheel to climb out or kick out. The wheel may either jump toward or away from the operator, depending on direction of the wheel's movement at the point of pinching. Abrasive wheels may also break under these conditions.

Kickback is the result of power tool misuse and/or incorrect operating procedures or conditions and can be avoided by taking proper precautions as given below.

- a] **Maintain a firm grip on the power tool and position your body and arm to allow you to resist kickback forces. Always use auxiliary handle, if provided, for maximum control over kickback or torque reaction during start-up.** The operator can control torque reactions or kickback forces, if proper precautions are taken.

- b) **Never place your hand near the rotating accessory.** Accessory may kickback over your hand.
- c) **Do not position your body in the area where power tool will move if kickback occurs.** Kickback will propel the tool in direction opposite to the accessory's movement at the point of snagging.
- d) **Use special care when working corners, sharp edges, etc. Avoid bouncing and snagging the accessory.** Corners, sharp edges or bouncing have a tendency to snag the rotating accessory and cause loss of control or kickback.
- e) **Do not attach a saw chain or toothed saw blade.** Such blades create frequent kickback and loss of control.

Safety Warnings Specific for Grinding Operations:

- a) **Use only wheel types that are specified for your power tool and the specific guard designed for the selected wheel.** Wheels for which the power tool was not designed cannot be adequately guarded and are unsafe.
- b) **The grinding surface of centre depressed wheels must be mounted below the plane of the guard lip.** An improperly mounted wheel that projects through the plane of the guard lip cannot be adequately protected.
- c) **The guard must be securely attached to the power tool and positioned for maximum safety, so the least amount of wheel is exposed towards the operator.** The guard helps to protect the operator from broken wheel fragments, accidental contact with wheel and sparks that could ignite clothing.
- d) **Wheels must be used only for specified applications. For example: do not grind with the side of cut-off wheel.** Abrasive cut-off wheels are intended for peripheral grinding, side forces applied to these wheels may cause them to shatter.
- e) **Always use undamaged wheel flanges that are of correct size and shape for your selected wheel.** Proper wheel flanges support the wheel thus reducing the possibility of wheel breakage. Flanges for cut-off wheels may be different from grinding wheel flanges.
- f) **Do not use worn down wheels from larger power tools.** Awheel intended for larger power

tool is not suitable for the higher speed of a smaller tool and may burst.

- g) **When using dual purpose wheels always use the correct guard for the application being performed.** Failure to use the correct guard may not provide the desired level of guarding, which could lead to serious injury.

Safety Warnings Specific for Sanding Operations:

- a) **Use proper sized sanding disc paper. Follow manufacturers recommendations, when selecting sanding paper.** Larger sanding paper extending too far beyond the sanding pad presents a laceration hazard and may cause snagging, tearing of the disc or kickback.

Safety Warnings Specific for Polishing Operations:



- a) **Do not allow any loose portion of the polishing bonnet or its attachment strings to spin freely. Tuck away or trim any loose attachment strings.** Loose and spinning attachment strings can entangle your fingers or snag on the workpiece.

Safety Warnings Specific for Wire Brushing Operations:

- a) **Be aware that wire bristles are thrown by the brush even during ordinary operation. Do not overstress the wires by applying excessive load to the brush.** The wire bristles can easily penetrate light clothing and/or skin.
- b) **If the use of a guard is specified for wire brushing, do not allow any interference of the wire wheel or brush with the guard.** Wire wheel or brush may expand in diameter due to work load and centrifugal forces.

Additional safety instructions

Particles generated when working with this machine can be harmful to health. This dust must not be allowed to enter your body. Do the following to reduce exposure to these substances:

- Ensure good ventilation of the workplace.
- Wear appropriate protective equipment, such as respirators able to filter microscopically small particles.
-  To protect your health, wear a suitable protective mask.
-  Always wear protective goggles to protect against sanding hazards.

- Connect the electric power tool to a suitable extraction system.
- Sweeping or blowing stirs up dust.
- Vacuum or wash the protective clothing. Do not blow, beat or brush.

Collect the generated particles at the source, avoid deposits in the surrounding area. Observe the relevant guidelines for your material, staff, application and place of application (e.g. occupational health and safety regulations, disposal). If potentially explosive or self-igniting dust is produced during sanding, the machining instructions issued by the material manufacturer must always be followed.

Metal and materials containing asbestos must not be processed.

Risk of fire! Avoid overheating the grinding material and the sander. Always empty the dust container before taking a break. Swarf in the filter bag or filter of the extraction system may self-ignite in unfavorable conditions such as flying sparks when grinding metals. Particular danger exists if the swarf is mixed with paint, polyurethane residue or other chemical materials and the grinding material is hot after long periods of work.

Damaged, eccentric or vibrating tools must not be used.

Always use an antistatic suction hose with the power tool. A slight electric shock may cause you to panic briefly and become distracted, which may result in an accident.

Start working with the lowest speed in order to get a feel for the machine.

Always use original ROKAMAT abrasives. Foreign abrasives are not suitable for the speed of the sander and may break.

Safety instructions for the protection of the electrical appliance

Do not overload the motor for a long period. Engine noise should be regular (not wave-like). Unsteady engine performance can be perceived acoustically.

Take a break when the machine is heated up strongly and let it cool down again. To that let the motor idle at top speed for some time.

Don't bend the flexible drive shaft!

Don't put the running motor on the ground! Dirt may get sucked in and cause damage.

Emission Levels

NOTE! Values for the A-weighted sound pressure level and for the total vibration values can be found in the "Technical specifications" table at chapter 4.

These values have been measured in accordance with a standardised test and may be used to compare one tool with another. They may also be used for a preliminary assessment of exposure.

CAUTION! The indicated measurements refer to new power tools represent the main applications of the tool. However, if the tool is used for different applications, with different accessories or poorly maintained, the vibration and noise emissions during actual use of the power tool may differ from the declared values (significantly increased over the total working period).



CAUTION! During operation the noise level can exceed 80 dB(A).

Wear ear protection!

Identify additional safety measures to protect the operator from the effects of vibration such as: maintain the tool and the accessories, keep the hands warm, organization of work patterns. An estimation of the level of exposure to vibration should also take into account the times when the tool is switched off or when it is switched on but running without load. This may significantly reduce the exposure level over the total working period.

Environmental conditions for machine, battery and charger

Operation

Temperature range: 0 °C to +50 °C
Humidity: ≤ 85 %, non-condensing
Climate: dry

Transport and storage

Temperature range tool: -5°C to +55°C
Temperature range battery: +10 °C and +30 °C
Humidity: 0 % to 70 %
Climate: dry, roofed, dew protected

3. Intended Use

The cordless handheld grinding, sanding, polishing, and wire brushing tool **Chameleon CX** is suitable for the following tasks on walls, floors, and similar surfaces:

- Sanding: polystyrene panels, rock wool lamellas, external thermal insulation composite systems (ETICS), plaster, fillers, wood, brick, screed, carpet and adhesive residues,

fiberglass-reinforced plastic (FRP), aerated concrete, and similar materials

- Removal: old plaster
- Smoothing: Shotcrete and other slippery surfaces
- Cleaning: Formwork, exposed concrete, buildings, and facades
- Polishing: Marble effect, wood and troweled precast concrete elements

Work on ceilings or similar overhead applications is expressly excluded from the intended use and must not be performed with this device. Work with the device may only be performed while standing securely on a stable surface. Work in which the operator is in an unstable position and must, for example, secure or hold themselves with one hand (e.g., on a ladder) is prohibited. Both hands must be free at all times to operate the device.

When performing grinding work or other dust-generating operations, the device must only be used in combination with a suitable dust extraction system.

This power tool is intended for use only with approved original ROKAMAT tools and accessories, as specified in the operating instructions.

Only sufficiently qualified and trained personnel is allowed to work with the *Chameleon CX*.

The intended use includes the observance of the operating instructions, in particular the safety instructions and the observance of generally recognized accident prevention regulations.

Any use other than the intended use described above is considered misuse. The manufacturer accepts no liability or warranty for misuse of the machine.

4. Technical Specifications

Chameleon CX Item No. 26000	
Rated voltage	18 V DC
No-load speed	120-400 min ⁻¹
Maximum tool diameter	200 mm
Driver disc	Fastening screw M6
Tool holder weight	2,4 kg
Total weight	4,9 kg
Dimension compact (LxHxW)	790x160x410 mm

A-weighted sound pressure level (see cap. 2 "Emission levels"):

Sound pressure level L _{pA}	88 dB(A)
Sound power level L _{WA}	99 dB(A)
Uncertainty K _{pA} , K _{WA}	3,0 dB

Total vibration value (see cap. 2 "Emission levels"):

Emission value a _h	2,0 m/s ²
Uncertainty K	1,5 m/s ²

5. Device Components

The specified illustrations can be found in fig. [1] on page 2 of the operating instructions.

- 1-1 Handle (Gripping surface)
- 1-2 Intake socket
- 1-3 Motor (with gripping surface)
- 1-4 Battery pack
- 1-5 Belt
- 1-6 Carabiner
- 1-7 Flexible drive shaft
- 1-8 Suction hood

6. Commissioning



WARNING!

Before switching on the power tool: Unpack power tool and accessories and check that no parts are missing or damaged.

Do not use this power tool until you have thoroughly read and fully understood the separate operating instructions for the battery packs and chargers.

Connecting the dust extraction system [2]

Push the suction hose [2-1] onto the intake socket [1-2]. Check for correct fit! If necessary, use a suitable adapter. See also chapter 7.

Motor mounting

The motor [1-3] is not allowed to be placed on the floor during operation, but must be hooked in the carabiner [1-6] of the provided belt [1-5] (resp. shoulder belt).

Switching the electric power tool on and off [4]

Switching on: Push the sliding switch [4-1] forward. For continuous activation, now tilt downwards until it engages.

Switching off: Press the rear end of the slide switch [4-1] and release it.

7. Instructions for Use



WARNING!

Risk of injury, electric shock!

Always remove the battery pack before performing any type of work on the machine!

Only use CAS-compatible chargers / batteries with a rated voltage of 18 V DC!

Charging the battery

See separate operating instructions for battery packs and chargers.

Installing or removing battery pack [3]



WARNING!

Risk of injury!

When removing and inserting the battery pack, hold the machine in such a way that the on/off switch cannot be actuated unintentionally!

To insert: Slide the battery pack [1-4] in until it engages.

To remove: Press the battery pack release button [3-4] and pull the battery pack downwards and out.

Rotating battery pack [7]

The rear section of the machine can be rotated 270° in three stages, thus allowing the machine's shape to be adapted to the working conditions. Only operate the machine when it is in an engaged position.

First press the locking button [3-1], rotate the rear part of the machine while keeping it pressed. Release the button while rotating the machine. The locking mechanism must engage with an audible "click".

Attaching and changing the abrasives with velcro [5]

- Remove the (worn) abrasives [5-1] from the supporting plates [5-3].

- Place the abrasives in the center of the supporting plates and press on.
- Conduct a test run to check that the abrasives are attached in the center.

Attaching, changing or removing the supporting plates [5]

- Take hold of the supporting plates with the grinding head to prevent the supporting plates from turning.
- Open the screw [5-2].
- The supporting plates can be detached/removed.
- Attaching in reverse order. Ensure that both pins on the driver disc [5-4] mate with the drill holes in the supporting plate.

Attaching and changing the tool discs without velcro [6]



CAUTION!

Never attach velcro-less tool discs without rubber washers! The rubber washers are needed to prevent the clamping screws from coming loose during operation. When installing tool discs, ensure that the **arrows on the discs** (if present) are aligned with the machine's turning direction.

- The supporting plates must be removed before tool discs [6-2] are mounted (see above).
- Centre tool discs directly on the driver disc. Ensure that both pins on the driver disc mate with the drill holes in tool discs.
- Then turn the clamping screws clockwise *together with the rubber washers* [6-1] to tighten them.
- Removing in reverse order.





ADVICE!

When using smoothing attachments (No. 25200), the appropriate base plate (No. 25000) must be used instead of the supporting plate!

Adjusting the speed [3]

Set the recommended speed at the thumbwheel [3-1] (small number = low speed; large number = high speed).

Dust extraction

  WARNING!
Health hazard posed by dust! Where required, always work with an extraction system and wear a protective mask. Observe national regulations.

The dust extraction system offered on our website is adapted to the quantity of dust generated and permanently ensure the necessary suction power.

 ADVICE!
Always use an antistatic suction hose! This helps reduce the electrostatic charge.

Suction hood [7]

To adjust the clearance for the suction hood, loosen the wing nuts [7-1], move the suction hood to the desired position (parallel to the working surface) and then retighten the wing nuts.

Distance of the dust exhausting cap has to be adapted to the height of the tool discs:

Sanding discs, JOEST Superpads, grinding grids, hard metal rasping discs: Adjust suction hood so far that discs project about 1 mm.

Widia discs and flattening discs (with trowel blades): Adjust suction hood so far that discs project about 1 – 1,5 mm.

This prevents the machine from canting. If the discs project too far, the points/blades will get too deeply into the render and cause stress to the machine.

Guide rails [8]

When working with **shaving plates, perforating discs, scratching discs and smoothing discs**, use **guide rails** (No. 22210) [8-1] as spacers instead of the suction hood.

To adjust the clearance for the guide rails, loosen the wing nuts and move the guide rails to the desired position (parallel to the working surface). Then, applying light pressure to the handle, simultaneously retighten the wing nuts.

Adjust guide rails in such way that discs project about 1-1,5mm.

8. Working with the Power Tool



1. Attach sanding tool.
2. Connect dust extraction system.
3. Attach motor to (shoulder) belt.
4. Set required speed.
5. Insert the battery pack.
6. Switch on dust extraction system.
7. Hold the grinder with both hands at the gripping surfaces.
8. Switch on the device.
9. Press the grinder gently against the work surface (the pressure should be just enough to ensure that the sanding head is flush with the work surface).
10. Swing the long neck grinder in overlapping movements to smooth the surface to the required fineness.

After finishing work

Once you have finished the grinding work, set the power tool down.

 CAUTION!
Do not set the power tool down with the grinding head facing downwards – always lay it on the floor so that it is on its side!

9. Maintenance and Care

   WARNING!
Risk of injury, electric shock! Always disconnect the mains plug from the socket before performing maintenance work on the machine!

Repairs may be carried out by an authorized customer service center only.

Repairs to electrical tools must be carried out by qualified electricians ONLY!

During the warranty period do not loosen the screws on the housing. Non-compliance will deem the warranty obligations of the manufacturer null and void.

Remove dust from the motor and battery regularly

It is possible that particles deposit inside the power tool during operation. This impairs the cooling of the power tool. Conductive build-up can impair the

protective insulation of the power tool and cause electrical hazards.

Transport and storage

 WARNING!
Risk of damage to the power tool! Remove the battery from the tool before transporting it! Transport and store the power tool only in its original carrying case.

Replacement of the flexible drive shaft [9]

 CAUTION!
The two boreholes for the push button at the drive shaft serve as length adjustment between shaft core and protective hose. The shaft core should be freely movable in length and must not get compressed!

Disassembling: On the motor side, press in the press button [9-2] in the borehole [9-3] with a tool (e.g. screwdriver) and pull out the protective hose [9-4]. Now the shaft core [9-6] can be replaced.

To replace the protective hose [9-4], it must also be loosened on the side of the tool holder. To do this, turn the protective hose [9-4], until the pushbutton [9-5] becomes visible in the borehole [9-1]. Press it down in with a tool (e.g. screwdriver) and pull out the protective hose [9-4].

Mounting: In reverse order. Make sure that the shaft core [9-3] is threaded into the square in each case.

 ADVICE!
Check all wearing parts once a month.

10. Spare Parts and Accessories

Other accessories, in particular insertion tools, can be found in the manufacturer's catalogues. Exploded drawings and spare-part lists can be found on our homepage: www.rokamat.com.

Use only original ROKAMAT spare parts and work tools!

11. Environmental Protection

The generated grinding dust may contain harmful substances. Dispose appropriately.

Observe national regulations on environmentally compatible disposal and on the recycling of disused machines, packaging and accessories.



For Great Britain and EU countries: Do not dispose of electric equipment or battery pack together with household waste material! In observance of the European Directives, on Waste Electric and Electronic Equipment and Batteries and Accumulators and Waste Batteries and Accumulators and their implementation in accordance with national laws, electric equipment and batteries and battery pack(s) that have reached the end of their life must be collected separately and returned to an environmentally compatible recycling facility.

 ADVICE!
Please ask your dealer about disposal options!

12. Declaration of Conformity

It is expressly declared that the cordless grinder listed on the first page under 1) from the serial number indicated onwards complies with all relevant provisions of the directives or regulations listed in 2) and that the harmonized standards listed in 3) have been applied. The technical documentation is available from the authorized documentation agent named in 4).

13. Troubleshooting

Problem	Possible causes	Remedy
Motor runs, but the supporting plate does not rotate.	Shaft core broken.	Exchange shaft core.
The electronic signal display [3-2] is permanently on and the load speed decreases.	There has been an overload while working, therefore the performance may be reduced temporarily.	Reduce working pressure.
The electronic signal display [3-2] flashes and the machine does not start.	The battery is empty, the temperature is too high or the restart protection has triggered.	Switch the machine off and back on again. The machine will not start if the battery pack is inserted while the machine is on. When using a battery pack that is not part of CAS, the machine will not start.
The machine has shut down by itself.	If the slew rate of the current is too high (for example, if the machine suddenly seizes or kickback occurs), the machine switches off. Switch off the machine.	Switch it on again and continue to work as normal. Try to prevent the machine from seizing.
<i>Chameleon CX</i> does not run smoothly over the surface.	Incorrect speed set.	Adjust speed.
	Suction pressure too high.	Reduce suction pressure: open suction flow regulator (if available).
	Tool discs are not mounted correctly.	Check the correct fit of the tool discs.
Excessive material removed from workpiece.	Suction hood / Guide rails set to wrong depth.	Adjust depth.
	Speed too high.	Reduce the speed.
	Grit on abrasives too coarse.	Select a finer grit.
Surface quality not perfect.	Incorrect or worn tool discs.	Select correct tool discs and check for good condition.
Perforating damages the wall surface	Guide rails set to wrong depth.	Adjust depth.
	Speed too high.	Reduce speed.
Wallpaper does not come off the wall.	Wallpaper was not fully soaked.	Increase soaking time and if necessary apply more water.
	Shaving plates mounted the wrong way round.	Check the turning direction.
	Guide rails set to wrong depth.	Adjust depth.
Extraction power is insufficient.	Filter element on the dust extraction system is blocked/clogged.	Clean the filter element regularly.
	Disposal bag inserted incorrectly.	Installing the disposal bag correctly.
	The suction power on the dust extraction system is too low.	Adjust the suction power to a higher setting.
	Speed too high.	Reduce speed.
	Suction hose blocked or kinked.	Remove blockage and straighten hose.
	Disposal bag full.	Dispose of the bag.
	Slide ring damaged.	Replace slide ring.

If problems other than those listed occur, please contact your ROKAMAT service workshop or your local specialist.